

---

**User's  
Manual**

**Model 701944/701945  
100:1 Probe**

---

---

## Introduction

This 701944 and 701945 probe is the high voltage probe with a 100:1 attenuation. The very sharp probe tip is spring loaded and minimizes the pressure to the device under test. It also prevents the probe from slipping on the board surface. In particular, the spring mechanism is useful when using the probe with it inclined. The probe tip is changeable. Replacement tips are provided in the accessory pack.

## Checking the Contents of the Package

If some of the contents are not correct, or if any items are missing or damaged, contact the dealer from which you purchased them.

701944/701945 probe main unit

Accessories

User's Manual (this manual):	1		
Pincher tip:	1	Standard ground lead:	1
Adjustment tool:	1	Rigid tip:	1
Spring tip*:	1	Color coding rings:	1 set
Insulation cap:	1	Protection cap**:	1

\*: Installed in the probe

\*\* : Plugged on the probe

## Revisions

1st Edition	November 2006
2nd Edition	March 2007

---

## Conventions Used in This Manual



Improper handling or use can lead to injury to the user or damage to the instrument. This symbol appears on the instrument to indicate that the user must refer to the user's manual for special instructions. The same symbol appears in the corresponding place in the user's manual to identify those instructions. In the manual, the symbol is used in conjunction with the word "WARNING" or "CAUTION."

### **WARNING**

Describes precautions that should be observed to prevent serious injury or death to the user.

### **CAUTION**

Describes precautions that should be observed to prevent minor or moderate injury, or damage to the instrument.

### **Note**

Provides important information for the proper operation of the instrument.

## Waste Electrical and Electronic Equipment (WEEE), Directive 2002/96/EC

(This directive is only valid in the EU).

This product complies with the WEEE Directive (2002/96/EC) marking requirement.

The following marking indicates that you must not discard this electrical/electronic product in domestic household waste.

Product Category

With reference to the equipment types in the WEEE directive Annex 1, this product is classified as a "Monitoring and Control instrumentation" product.

Do not dispose in domestic household waste.

When disposing products in the EU, contact your local Yokogawa Europe B. V. office.

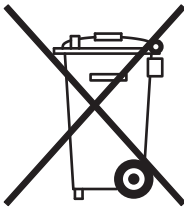

---

## Safety Precautions

To safely operate this product and to fully utilize its functionality, strictly observe the following cautions.

This product complies with the requirements stated in measurement categories I and II, and pollution degree 2 defined in IEC61010-031.

If this probe is operated in a manner not specified in this manual, this may cause the protection capability of this product to lessen. Additionally, YOKOGAWA shall not be held responsible for defects arising from negligence of such warning and caution, and also shall not guarantee the product in such case. Before using this probe, thoroughly read the instruction manual for measuring instrument to fully understand the specifications and handling precautions for safe and correct operation.



---

### WARNING

- **Grounding of the measuring instrument**  
The protective grounding terminal of the measuring instrument must be connected to ground.
  - **Ground lead of the probe**  
Make sure to connect the ground lead of the probe to the ground (ground potential).
  - **Connecting the object of measurement**  
Make sure to avoid an electric shock when connecting the probe to the object of measurement. Do not remove the probe from the measuring instrument after the object of measurement is connected.
  - **Do not operate with suspected failures**  
If you suspect that there is damage to this probe, have it inspect by a service personnel.
  - **Maximum input voltage**  
Do not apply any voltages exceeding the maximum input voltage to the probe.
  - **Do not operate in wet/damp conditions**  
To avoid electric shock, do not operate this probe in wet or damp conditions.
  - **Do not operate in explosive atmosphere**  
To avoid injury or fire hazard, do not operate this probe in an explosive atmosphere.
  - **Avoid exposed circuitry**  
To avoid injury, remove jewelry such as rings, watches, and other metallic objects. Do not touch exposed connections and components when power is present.
-

# Specifications

The specifications described in this section apply to the probe connected to Yokogawa's oscilloscope model DL series and may vary depending on the type of oscilloscope connected. The preconditions for the following specifications are that the instrument should be warmed up for at least 20 minutes and the environmental conditions should not exceed the specified limits of the probe.

## Electrical Specifications

Item	701944	701945
Attenuation Ratio*	100:1 ± 2% (DC)	100:1 ± 2% (DC)
Voltage Coefficient	0.0005 %/V (typical value)	0.0005 %/V (typical value)
System Bandwidth**	400 MHz (-3 dB)	250 MHz (-3 dB)
Probe Rise Time	< 900 ps (10% to 90%)	< 1.4ns (10% to 90%)
Maximum Input Voltage***	1000 Vrms	1000 Vrms

\*: This specification value is obtained when the probe is connected to an oscilloscope having an input resistance of 1 MΩ ± 1%.

\*\* : This specification value is obtained when the probe is connected to an oscilloscope having a bandwidth of 500 MHz or greater.

When the probe is connected to an oscilloscope having a bandwidth of less than 500 MHz, depends on the bandwidth of the oscilloscope main unit.

\*\*\*: See the compatible standards shown below. See also "Voltage Derating".

## Electrical Characteristics

Input Resistance (system)	50 MΩ ± 1%
Input Capacitance (system)	7.5 pF (typical value)
Input Impedance (system)	See also "Input Impedance."
Compensation Range	10 pF to 50 pF (typical value)
Input Coupling of the measuring instrument	1 MΩ DC/AC

## Mechanical Characteristics

Weight (probe only)	Approximately 55 g
Cable Length	Approximately 1.2 m(701944), 3 m(701945)

## External Dimensions

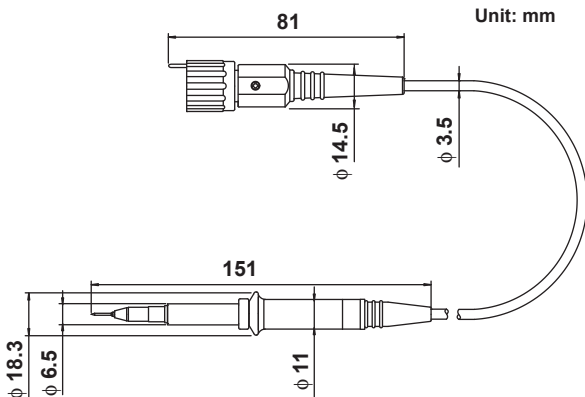

---

## Environmental Specifications

---

Altitude	Operating: Up to 2000 m Storage: Up to 15000 m
Temperature Range	Operating: 0 °C to 50 °C Storage: - 40 °C to 71 °C
Maximum Relative Humidity	Operating: Relative humidity of 80% at a temperature of up to 31 °C, decreasing linearly to relative humidity of 40% at 50 °C if the temperature is 31 °C or higher.

---

## Standards Compliance

This product is compliance with the following categories of IEC61010-031:

Measurement Category I	1000 Vrms, 4000 V transient over-voltage
Measurement Category II	1000 Vrms CATII
Pollution Degree 2	Normally, only non-conductive pollution occurs. Occasionally, however, a temporary conductivity caused by condensation must be expected.

---

## Definitions and Examples of IEC Measurement Category

Measurement category II (CAT II)	Definition: Measurement category II is for measurements performed on circuits directly connected to the low voltage installation. Examples: Measurement on household appliances, portable tools, and similar devices.
Measurement category I	Definition: Measurement category I is for measurements performed on circuits not directly connected to a main supply. Examples: Measurements in circuits not derived from a main supply and specially protected (internal) circuits derived from a main supply.

# Voltage Derating

## CAUTION

- As the frequency of the input signal increases, the maximum rating of the input voltage of the probe decreases. For details about appropriate input voltage, see Section 3, Specifications.

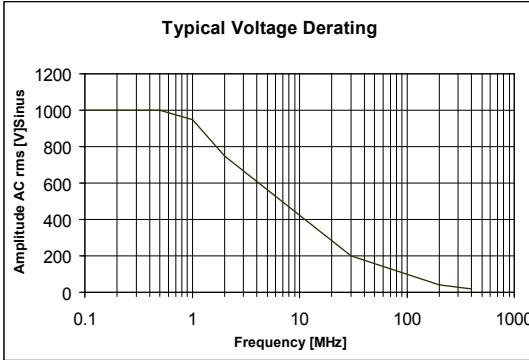

# Input Impedance

## CAUTION

- As the frequency of the input signal increases, the input impedance of the probe decreases.

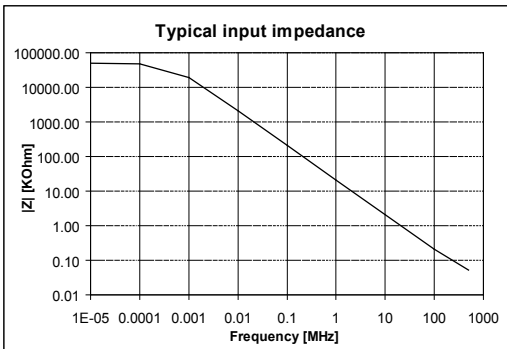

# Maximum Pulse Ratings

For pulse measurements make sure to comply with the ratings as shown below.

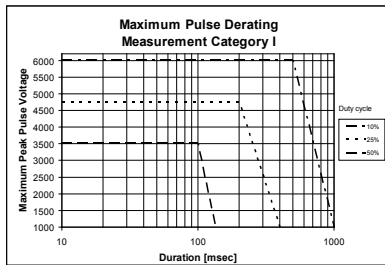
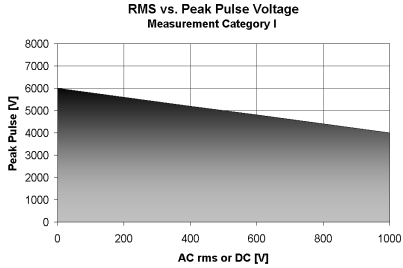



# Handling

## CAUTION

- Since the spring type contact tip is very thin and sharp, great care should be taken to prevent personal injury when the contact tip is mounted. In particular, handle the spring type contact tip with great care. The probe cable is a delicate part of the probe. If the probe cable is bent or pulled forcibly, this may cause the cable to break. To keep the accuracy and protect the product, do not apply any impact or shock to the product.
- Cautions When Using the Probe with DL1700 Series Instruments  
Yokogawa DL1700 series digital oscilloscopes (excluding the DL1700E) have two different types of probe connectors (A and B in the figure below). Be sure to check which type of probe connector your DL1700 series instrument uses. If the probe connector is of type B, you must use an anti-interference sheet. This sheet is provided free of charge by contacting your nearest Yokogawa representative. If the anti-interference sheet is not used, part of the probe can become caught on and potentially damage the front bezel, or become unable to be disconnected. If probe connector type A is used on your DL1700 series instrument, the anti-interference sheet is not required.

Probe connector type

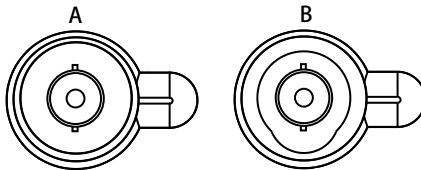

Affixing the Anti-Interference Sheet

Affix the anti-interference sheet to the DL1700 series instrument's probe connector as shown in the figure below.

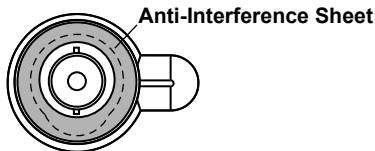

## Maintenance

### Cleaning

When cleaning the exterior of the probe, clean it using a soft cloth rag moistened with either water or isopropyl alcohol. In this case, dry the probe completely before starting the measurement.

### Changing the Probe Tip

To change the probe tip, grip the tip firmly with pliers and carefully pull it straight out of its contact socket along the axis of the probe. Do not grip the white plastic insulator or the housing with pliers, because this will damage the probe tip. If the probe tip is removed, the new tip can be inserted with pliers into the socket, along the axis of the probe. To insert the probe tip completely into the housing, press the probe tip against a hard surface carefully.

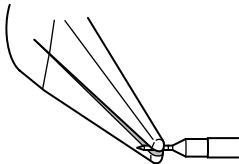

Use pliers to grip and pull the probe tip carefully out of its contact socket.

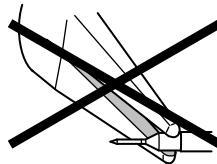

Do not grip the white plastic insulator or the housing with pliers.

## Adjustment Procedures

### LF Compensation

LF needs to be adjusted when the probe is connected to the scope input the first time. LF compensation matches the probes cable capacitance to the oscilloscope input capacitance. This matching assures good amplitude accuracy from DC to upper bandwidth limit frequencies. A poorly compensated probe clearly influences the overall system performance (probe + scope) and introduces measurement errors resulting in inaccurate readings and distorted waveforms.

LF compensation is performed by connecting the probe to the COMP-output on the oscilloscope and adjust the LF compensation trimmer (see also the Figs. below.) optimum square wave response.

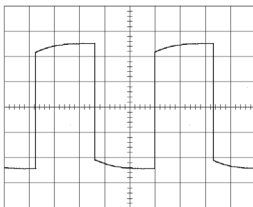

Under compensated

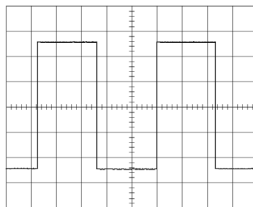

Optimum

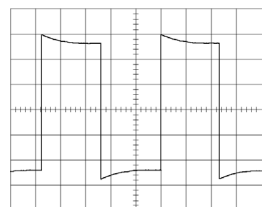

Over compensated

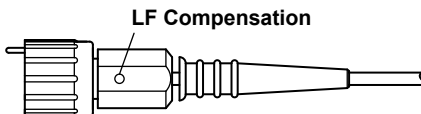

## HF Compensation

HF needs to be adjusted when the probe is connected to the scope input the first time.

HF adjustment is performed by connecting the probe to a rectangular wave generator with first rise time. Adjust the trimmer for optimum wave response.

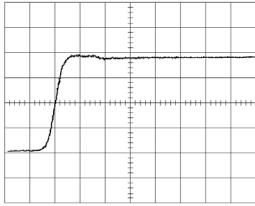

Optimum

## DC Adjustment

In order to provide highest accuracy this probes dividing ratio is factory adjusted using 500 VDC source and measuring device with a precision input impedance of  $1\text{ M}\Omega \pm 1\%$ .

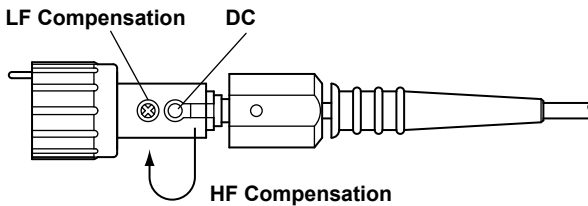

## Replaceable Parts

Replaceable parts are prepared as sets. When ordering any replaceable part set, inform a desired set name and its part number.

Accessories Basic(part number: B9852HK)

Pincher tip:	2
Standard ground lead:	2
Rigid tip:	2
Spring tip:	2

Accessories HV(part number: B9852HL)

Safety Alligator Clip:	2
Flexible Adapter:	1
Ground Lead 22 cm to 4 mm banana plug:	1

# List of Accessories

## CAUTION

- Use ground lead only for grounding connections.
- Do not use any accessories other than those originally provided.

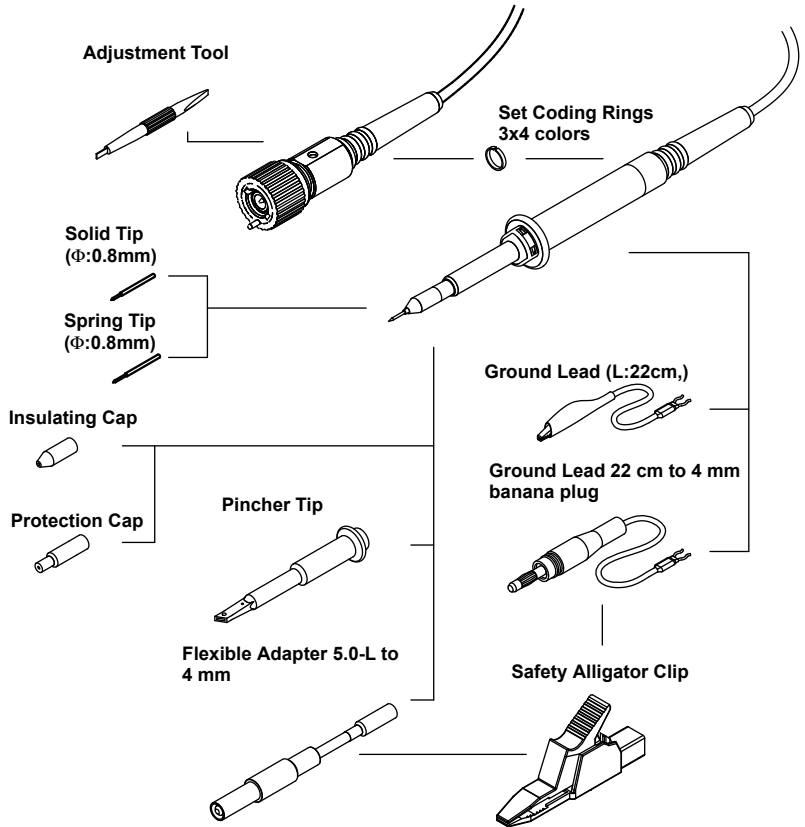

---

YOKOGAWA ELECTRIC CORPORATION, Communication & Measurement Business Headquarters

Phone: (81)-422-52-6768, Fax: (81)-422-52-6624, E-mail: [tm@csv.yokogawa.co.jp](mailto:tm@csv.yokogawa.co.jp)

YOKOGAWA CORPORATION OF AMERICA

YOKOGAWA EUROPE B.V.

Phone: (1)-301-916-0409, Fax: (1)-301-916-1498

Phone: (31)-33-4641858, Fax: (31)-33-4641859

YOKOGAWA ENGINEERING ASIA PTE. LTD.

Phone: (65)-62419933, Fax: (65)-62412606

---